MVG

Installation Guide



SerVision

February
2011

Trademarks & Copyright

Trademarks

All trademarks mentioned in this manual are the sole property of their respective manufacturers.

Copyright

SerVision Ltd., Jerusalem, Israel

www.servision.net • info@servision.net

© 2011 SerVision Ltd. All rights reserved.

Notice

Information in this document is subject to change without notice. SerVision Ltd. assumes no responsibility for any errors that may appear in this manual. Companies, names and data used in examples herein are fictitious unless otherwise noted. No part of this document may be copied or reproduced in any form, or by any means, electronic or mechanical, for any purpose, without the express written permission of SerVision Ltd. SerVision Ltd. makes no warranties with respect to this documentation and disclaims any implied warranties of merchantability or fitness for a particular purpose.

Table of Contents

Introduction	3
The MVG Package	4
Additional Equipment	6
Installing the MVG System	8
Selecting a Location for the Unit	9
Preventing Overheating	9
Installing the Unit	10
Diagram of the Rear Panel	11
Supplying Power to Devices Connected to the Unit	13
Turning the Device Power On and Off with the Ignition	14
Transforming the Supplied Voltage to 12V	14
Configuring the Power-Supply Activator	15
Connecting Devices to the MVG	17
Connecting Cameras	17
Connecting PTZ Controllers	17
Connecting Sensors	19
Connecting a Sensor Directly to the Unit	19
Connecting Sensors Using an ADAM Module	20
Connecting Activators	23
Connecting Sensors and Activators Using an IA Relay Board	24
Connecting Microphones	25
Connecting a Speaker or Headphones	26
Connecting a CCTV Monitor	26
Connecting a Switch	28
Connecting Multiple Monitors	28
Setting Up Network Connections	29
Connecting the MVG to an External Network	29
Connecting Devices to the MVG's Internal Network	29
Connecting the GPS Antenna	31
Connecting the MVG to a Power Source	32
Connecting the Unit to the Vehicle Battery	32
Connecting the Unit to an Electrical Outlet	35
Appendix: Removing the Unit's Hard Drive	36

Introduction

This guide explains how to set up the hardware components of SerVision's MVG security system. The MVG belongs to SerVision's line of TVG video gateway units. These units provide state-of-the-art security functionality, including live video streaming, video recording and playback, motion detection, sensor management, real-time event notification, and device activation. All of these features can be accessed remotely via PC, PDA, or cellular telephone.





The MVG is optimized for deployment in vehicles. It has built-in support for cable-based, WiFi, and cellular networking, and contains an internal GPS receiver that makes it possible to track the location and route of the vehicle in which it is installed.





Once the MVG has been installed as explained in this guide, it must be configured. Configuration is performed by connecting to the MVG unit using a PC that is on the same network as the unit (or connected to the unit directly using a LAN cross cable) and opening the unit's configuration utility in a browser. For additional information about configuring your MVG, please refer to the *TVG System Guide*.

Client software is used for accessing the MVG unit remotely in order to view video and events and control the system in various ways. SerVision offers client software for PCs and for certain cellular telephone and PDA models. Full instructions for the use of the client applications are available in separate manuals, which can be downloaded at <http://www.servision.net>.

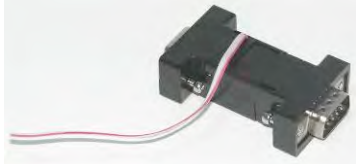
The MVG Package

The MVG package contains the following items:

Item	Description	Illustration
MVG unit	Video gateway	 <p>A grey rectangular device with 'SerVision' and 'MVG-400' printed on the front. It has two indicator lights labeled 'HDD' and 'POWER' on the right side.</p>
Power supply cable	Connects the unit to an electrical outlet	 <p>A black power supply cable with a green terminal block on one end and a power plug on the other.</p>
Power cord	Connects the unit to the vehicle battery via the cigarette lighter	 <p>A red power cord with a black cigarette lighter plug on one end and a green terminal block on the other.</p>
Ethernet (LAN) cable	Connects the unit to a PC (or a cable-based local network)	 <p>A standard white Ethernet (LAN) cable with RJ45 connectors on both ends.</p>
RS232/485 serial adapter	Connects PTZ controllers to the unit	 <p>A small black electronic component with a multi-pin connector on one side and a ribbon cable on the other.</p>

Item	Description	Illustration
GPS antenna	Enables the built-in GPS receiver to connect to satellites	
2 supports	Used to install the unit in the vehicle	
4 screws	Used to connect the supports to the unit	
4 washers	Used to connect the supports to the unit	

Additional Equipment

Up to four video cameras can be connected to the MVG. You must acquire the cameras you require; they are not included in the MVG package. For information about camera compatibility and about connecting the cameras to the unit, see *Connecting Cameras*, page 17, or consult your vendor.

In addition to the cameras, you may wish to incorporate some or all of the optional equipment listed below into your security system. For additional information about these items and the cables required to connect them, please refer to the installation instructions for each type of device.

NOTE: This equipment is not included in the MVG package.

- Cellular modem with USB adaptor (see *Connecting the MVG to an External Network*, page 29)
Note: Not all cellular modems are supported. Please contact your MVG supplier or SerVision technical support for a list of supported cellular modems.
- USB extension cord for connecting the cellular modem to the unit; the modem functions best if it is installed high in the vehicle in an exposed location (see *Connecting the MVG to an External Network*, page 29)
Note: The extension cord should not be longer than about 1.5 meters.
- WiFi card with USB adaptor (see *Connecting the MVG to an External Network*, page 29)
Note: Not all WiFi cards are supported. Please contact your MVG supplier or SerVision technical support for a list of supported WiFi cards.
- Up to four dry-contact sensors (see *Connecting Sensors*, page 19)
Note: Up to four dry-contact sensors can be connected directly to the MVG unit. If you use either an ADAM module or an IA relay board, as described below, you can connect an additional 16 dry-contact sensors via the unit's **RS232/485** connector.
Note: If you connect a touchscreen monitor to the MVG, you cannot also connect an ADAM module or an IA relay board. In this case, you can only connect up to four dry-contact sensors to the unit.
- ADAM Data Acquisition Module and ADAM isolated RS232->RS422/RS485 converter, for connecting up to 16 dry-contact sensors (see *Connecting Sensors*, page 19)
- Intelligent Appliance IA-3126-2 relay board, for connecting up to 16 dry-contact sensors (see *Connecting Sensors and Activators Using an IA Relay Board*, page 24) and 16 activators to the MVG unit
- Up to two dry-contact activators (alarms or other devices that are turned on or off in response to the activation of a sensor; see *Connecting Activators*, page 23)
Note: Up to two activators can be connected directly to the MVG unit. If you use an IA relay board, as described above, you can connect an additional 16 activators via the unit's **RS232/485** connector.
Note: If you connect a touchscreen monitor to the MVG, you cannot also connect an IA relay board. In this case, you can only connect up to two dry-contact activators to the unit.
- Up to two microphones (see *Connecting Microphones*, page 25)
- Speaker or headphones (the unit already contains a built-in speaker; see *Connecting a Speaker or Headphones*, page 26)
- CCTV monitor for closed-circuit video display (see *Connecting a CCTV Monitor*, page 26)
- Push-button switch to change the display in a connected CCTV monitor (see *Connecting a Switch*, page 28)
- Toggle (on-off) switch to change the active outline (see *Connecting Sensors*, page 19)

- For units that will be installed in a truck or bus, an insulated container with a built-in fan in which the MVG unit can be placed (see *Preventing Overheating*, page 9)
- Additional hard drives (see *Appendix: Removing the Unit's Hard Drive*, page 36)

Installing the MVG System

These are the steps that you will typically follow in order to install the MVG system:

1. Install the MVG unit in its desired location using the supplied supports; see *Selecting a Location for the Unit*, page 9.
Note: If you are installing the MVG in an insulated container (see *Preventing Overheating*, page 9), you must install the container in the vehicle and the MVG in the container.
2. Install the video cameras in their desired locations.
3. Install the sensors in their desired locations (optional).
Note: Four sensors can be connected directly to the unit; another 16 can be connected through an ADAM module or an IA relay board; see *Connecting Sensors*, page 19.
4. Install a toggle switch in its desired location (optional); the toggle-button switch can be used to change the active outline; see *Connecting Sensors*, page 19.
5. Install the activators in their desired locations (optional).
Note: Two activators can be connected directly to the unit; another 16 can be connected through an IA relay board; see *Connecting Activators*, page 23.
6. Install a CCTV monitor in its desired location (optional).
7. Install a push-button switch in its desired location (optional); the push-button switch can be used to change the display on the CCTV monitor, if a monitor is connected to the unit; see *Connecting Sensors*, page 19.
8. Connect the cameras and other devices to the MVG, as required; see *Connecting Devices to the MVG*, page 17.
9. Connect the cameras and other devices to the vehicle battery, as required; see *Supplying Power to Devices Connected to the Unit*, page 13.
10. Place the cellular modem in an appropriate location in the vehicle and connect it to the unit using a USB extension cord (optional); see *Connecting the MVG to an External Network*, page 29.
11. Connect the WiFi adaptor to the unit (optional); see *Connecting the MVG to an External Network*, page 29.
12. Connect the unit to a LAN using an Ethernet cable (optional); see *Connecting the MVG to an External Network*, page 29.
13. Install the GPS antenna in an appropriate location in the vehicle and connect it to the unit (optional); see *Connecting the GPS Antenna*, page 31.
14. Install any devices that will be connected to the MVG's internal network in their desired locations. Connect them to a power source and to the unit (optional); see *Connecting Devices to the MVG's Internal Network*, page 29.
15. Connect the MVG unit to a power source; see *Connecting the MVG to a Power Source*, page 32.

NOTE: The unit, the devices connected to it, and the cables used to connect them, must all be securely fastened to the vehicle to ensure they do not become detached from their locations when the vehicle is in motion.

NOTE: Installing the unit and its peripheral equipment in a vehicle is a complex process. It is highly recommended that it be performed by a trained specialist in vehicle installations.

Selecting a Location for the Unit

The unit should be installed in a cool and ventilated location, protected from direct sunlight and water. It should not be installed in a closed location, such as the in the trunk or dashboard, or under the paneling, of a car. Ensure the unit has at least a few centimeters (1–2 inches) of space above it and on all sides for ventilation. It can be installed either horizontally or vertically.

When choosing a location for the MVG, bear in mind that the unit must be connected to the vehicle battery and ignition (if required), that other devices (cameras, sensors, PC, etc.) must be connected both to it and to power sources, and that the GPS antenna and cellular modem must be located relatively high up and in exposed locations (see *Connecting the MVG to an External Network*, page 29; *Connecting the GPS Antenna*, page 31). Choose a location in which these connections are feasible.

Preventing Overheating

MVG units that are installed in cars should be placed in the passenger compartment in a location that is cooled by the car's air-conditioning when the air conditioner is on.

Units that are installed in trucks or buses should be installed in an insulated container with a built-in fan. Containers of this type are available for purchase from vehicle-accessory suppliers. The container should be installed in the vehicle in an accessible location, with as much ventilation as possible. The cellular modem, and the end of the GPS antenna, should be placed outside the container. (The cellular modem should be connected to the MVG unit using a USB extension cord; see *Connecting the MVG to an External Network*, page 29.)



Figure 1: MVG installed in an insulated container

Installing the Unit

The unit should be firmly secured to ensure it does not move around when the vehicle is in motion; if the unit is dislodged from its location in the vehicle, it may be damaged, hit people in the vehicle, or harm other items with which it comes into contact.

NOTE: To install the unit, you will need screws to secure the unit to its anchoring surface (not supplied; see step 2 below).

⇒ To install the MVG:

1. Connect the two side supports to either side of the bottom of the MVG, using two screws and two washers for each support. (The screws and washers are included with the MVG.)



Figure 2: Side support



Figure 3: Supports attached to bottom of the MVG

- Place the unit in the desired location and attach it securely by connecting the side supports to the anchoring surface with two or three screws on each side. (These screws are not included with the MVG.)

Note: The unit can be placed horizontally or vertically. If it is placed vertically, the left side (the side containing the hard drive) should face up.



Figure 4: Hard-drive compartment

Diagram of the Rear Panel

The rear of the MVG unit contains the connectors and controls described below.

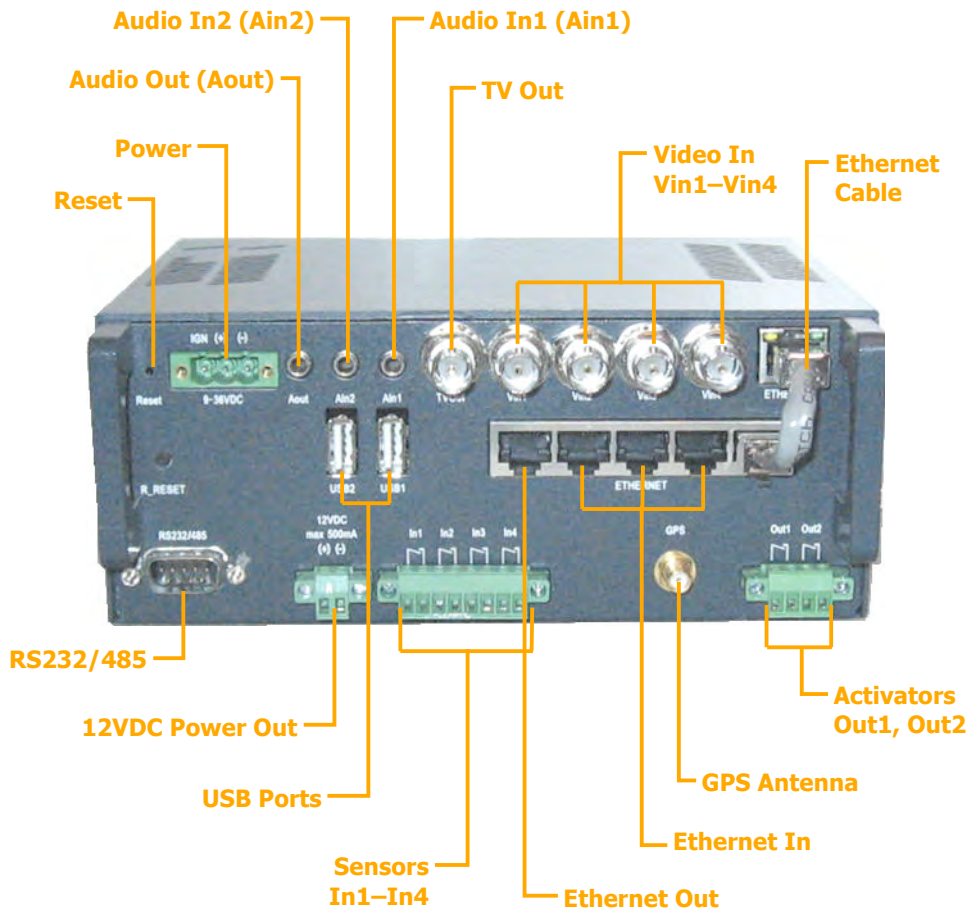

Figure 5: MVG connectors and controls

Connector/Control	Description
Reset	Reset button. Use a pin to press the button when it is necessary to reset the unit manually. Note: Your configuration settings will not be lost during a reset.
Power	Connector for the power supply and, if required, for the ignition connection (see page 32)
Audio Out (Aout)	Connector for an external speaker or headphones (see page 26)
Audio In2 (Ain2)	Connector for an active microphone (see page 25)
Audio In1 (Ain1)	Connector for a passive microphone (see page 25)
TV Out	Connector for a CCTV monitor (see page 26)
Video In (Vin1–Vin4)	Connectors for video cameras (see page 17)
Ethernet Cable	Cable connecting the video gateway component of the MVG to the unit's router. Do not disconnect.
RS232/485	Serial (COM) port for PTZ controllers (see page 17), ADAM modules (see page 20), a touch-screen controller (see page 26), a device to receive GPS location data (for additional information, consult your vendor), or technicians' use
12VDC Power Out	Supplies power to external devices, such as cameras and sensors (see page 13) Note: The unit can supply up to 500 mA of power.
USB Ports	Connectors for a WiFi card and/or cellular modems with USB adaptors (see page 29)
Sensors (In1 – In4)	Sensor connectors (see page 19)
Ethernet Out	10/100 Base-T LAN connector for connecting the unit to an external network (LAN or WAN; see page 29.)
Ethernet In	Three 10/100 Base-T LAN connectors for connecting other devices to the internal network managed by the MVG's router (see page 29)
GPS Antenna	GPS antenna connector (see page 31)
Activators (Out1, Out2)	Activator connectors (see page 23)

Supplying Power to Devices Connected to the Unit

The MVG can supply power from the vehicle battery directly to cameras and other devices via the **12VDC Power Out** connector on the rear panel of the unit. However, only a limited amount of power can be supplied by the MVG in this way. If the devices connected to the **12VDC Power Out** connector draw too much power, the unit may overheat or otherwise malfunction. Therefore, it is best to provide independent power supplies for devices connected to the unit whenever possible by connecting them directly to the vehicle battery (or some other power source).

The unit can supply a maximum of 500 mA (6W at 12V) of power through the **12VDC Power Out** connector. Typically, this means it can power at most two cameras. Nonetheless, you must consult the device documentation to ascertain the actual power usage of each device you want to connect to the MVG unit. For example, if one camera uses 150 mA and another uses 250 mA, the total power usage of the two cameras is 400 mA. Since the MVG can supply a maximum of 500 mA, this means that 100 mA are available for other devices when these two cameras are connected to the **12VDC Power Out** connector on the MVG.

NOTE: It is, of course, possible to connect some devices to the **12VDC Power Out** connector on the MVG and others directly to the vehicle battery – as long as the total power consumption for the devices connected to the **12VDC Power Out** connector does not exceed 500 mA.

Turning the Device Power On and Off with the Ignition

Normally, the MVG is configured to shut down whenever the vehicle ignition is turned off. All devices that draw their power through the **12VDC Power Out** connector on the MVG are also turned off when the MVG shuts down, because they do not receive any power from the unit. If you want devices that receive their power independently to also shut down when the vehicle ignition is off, you should route the independent power supply through one of the activator connectors (**Out1** or **Out2**) on the MVG unit, as illustrated below.

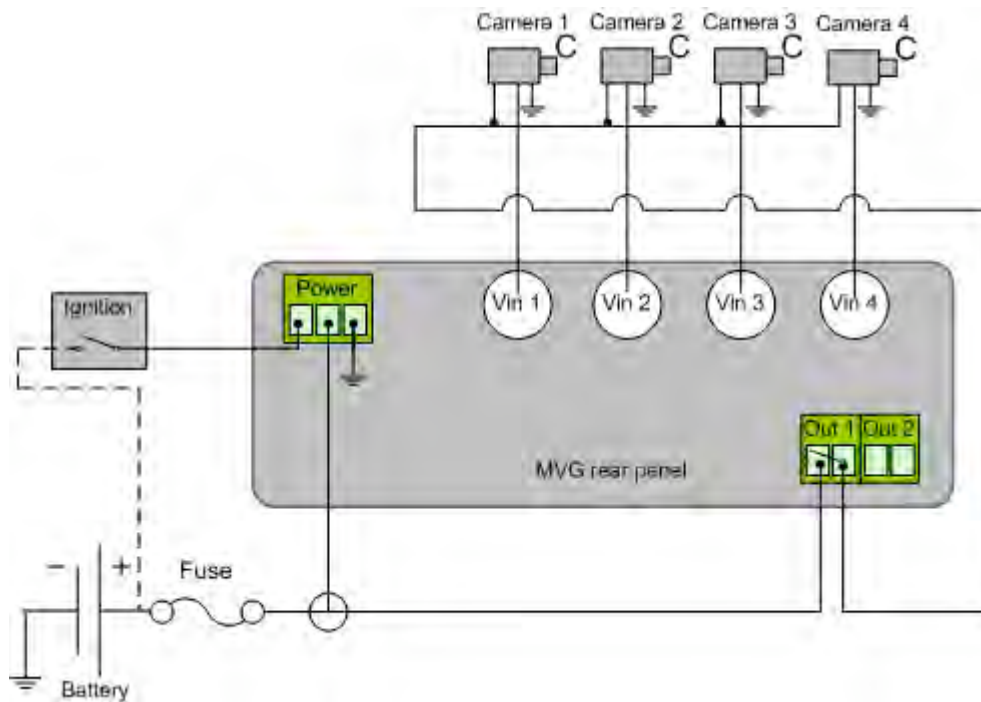

Figure 6: Connecting cameras to the power supply through an Activator connector

Transforming the Supplied Voltage to 12V

When the power supply for one or more devices is routed from the vehicle battery, you must ensure that the voltage reaching the devices is 12V. If the vehicle battery supplies power at a voltage other than 12V, you must insert a transformer between the battery and the device, as in figure 7 below.

In order to ensure that the transformer is compatible with the vehicle battery, it is recommended that it be purchased in the country in which it will be used. In addition, make sure the capacity of the transformer is more than sufficient for all of the devices connected to it. You can calculate the required capacity by calculating the sum of the power consumptions of each device drawing power from the battery through the line. For example, if four cameras and two sensors are connected directly to the battery, and each one uses 2W, the total requirement is 12W. Allow an additional margin of 20-30% when you select the transformer. Thus, if the devices require a total of 12W, get a transformer that supplies at least 14.4W.

NOTE: You can convert Amps to Watts using the following formula:

$$\text{Volts} * \text{Amps} = \text{Watts}$$

For example, a 12V device that operates at 250 mA consumes 3 Watts: $12 * 0.25 = 3$.

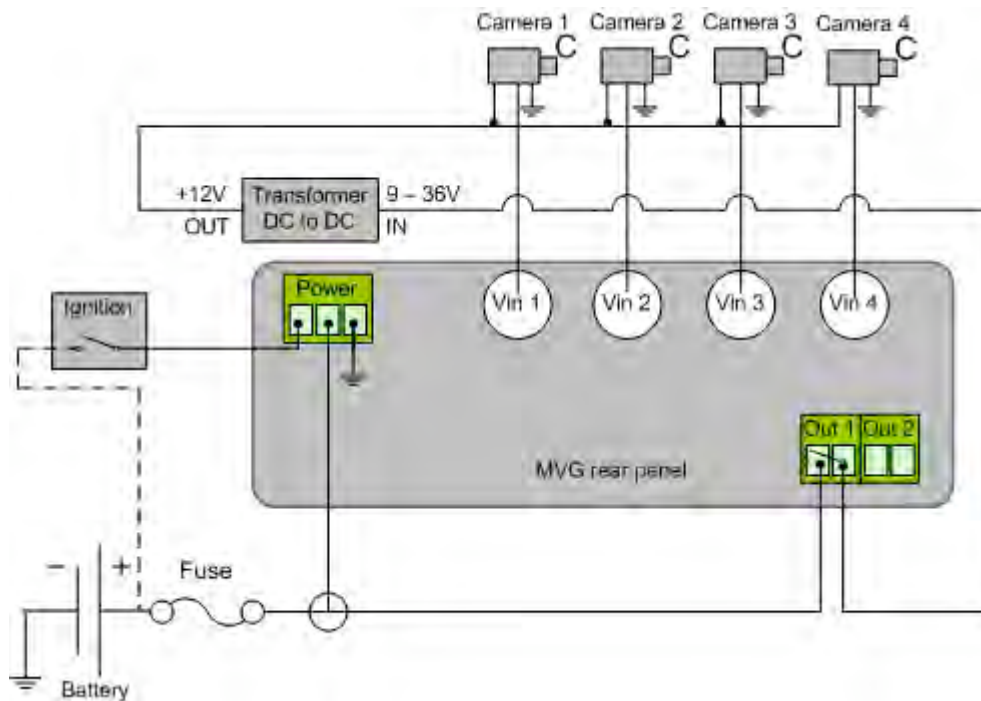

Figure 7: Placing a transformer between the vehicle battery and the devices drawing power from it

Configuring the Power-Supply Activator

When the power supply to devices is routed through an activator connector, as described above, the activator must be configured correctly in the MVG's configuration: the **Normal Status** of the activator must be set to **Closed**, as in the illustration below. (For additional information about configuring the activator, please refer to the *TVG System Guide*, under *Configuring Sensor and Activator Settings*.)

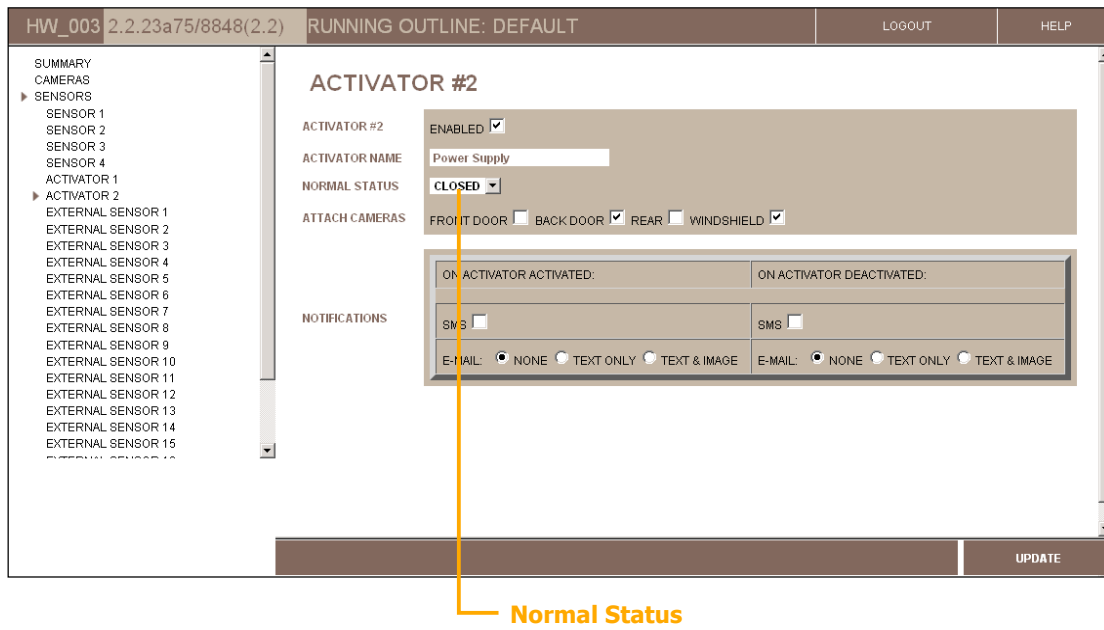

Figure 8: Normal Status of activator set to Closed

Connecting Devices to the MVG

This section explains how to connect cameras, sensors, activators, microphones, a speaker or headphones, and a CCTV monitor to the MVG unit.

NOTE: Make sure that all installed devices are designed to function properly under mobile conditions (temperature range, vibrations, power supply, etc), that they are all installed in accordance with their manufacturer's requirements, and that the devices and all cables are properly installed and firmly fastened so that they will not become dislodged when the vehicle moves. It is highly recommended to consult vehicle experts before installing external devices.

Connecting Cameras

Up to four cameras can be connected to the MVG. If the cameras have PTZ controls for remote aiming and zooming, and the PTZ protocols they use are supported, the control cables can also be connected to the unit.

Any PAL or NTSC video camera with a composite video output can be connected to the unit. A cable with a composite video connector on one end, and a male BNC connector on the other, should be used to connect each camera to the MVG.

NOTE: A cable with a male RCA connector can be connected to a female BNC connector by using an RCA-to-BNC adaptor.



Figure 9: RCA-to-BNC adaptor

Cameras that are connected to the MVG can receive their power from the vehicle battery via the MVG unit through the **12VDC Power Out** connector on the rear panel of the unit. However, bear in mind that the unit can supply a maximum of 500 mA (6W) of power through this connector. Typically, this is only enough power for two cameras. If the devices connected to the unit require more than this amount of power, you must power some or all of them independently by connecting them directly to the vehicle battery (or some other power source), as explained under *Supplying Power to Devices Connected to the Unit*, page 13.

➡ **To connect a camera:**

1. Install the camera in its desired location.
2. Connect the output of the camera to one of the **Video In** connectors on the rear panel of the unit.
3. Connect the camera's power connector to a power source .

Connecting PTZ Controllers

If a camera has remote PTZ control features (pan, tilt, zoom, and/or focus), and uses a supported PTZ protocol, you can connect the control cable to the unit. Both RS232 and RS485 PTZ connection types are supported. Consult the camera documentation for information about which connection type to use.

NOTE: If you are connecting sensors to the unit using an ADAM module, or you are using the **RS232/485** connector to connect a touchscreen CCTV monitor to the unit, you cannot connect any RS232 PTZ controllers. For additional information, see *Connecting Sensors Using an ADAM Module*, page 20; *Connecting a CCTV Monitor*, page 26.

If you want to connect the PTZ controllers of multiple cameras to the unit, only one of the controllers can use an RS232 connector – the others must all use RS485 connectors. PTZ controllers for more than one RS232 camera cannot be connected to the unit simultaneously.

If you connect multiple RS485 PTZ camera controllers, they should be daisy-chained to the **RS232/485** connector, as described below. In this case, each camera in the chain must be given a different ID number. Please refer to your camera's documentation for information about configuring its ID number. In addition, note that you can only create an RS485 daisy chain if every link on the chain (i.e., every camera) uses the same PTZ protocol. Attempting to connect cameras that use different protocols will prevent all of the cameras from working properly.

⇒ **To connect an RS232 PTZ controller:**

The RS232 controller cable should end with a female 9-pin RS232 connector.

- If you are only connecting the RS232 PTZ controller to the unit, and are not connecting any RS485 PTZ controllers, plug the 9-pin RS232 connector directly into the **RS232/485** connector on the rear panel of the unit.
- If you are also connecting one or more RS485 PTZ controllers to the unit, plug the 9-pin RS232 connector into the RS232/485 adapter supplied with the unit.

⇒ **To connect an RS485 PTZ controller:**

Each RS485 controller cable should end with two wires.

1. Use a wire connector to connect the wires to the RS485 connection wires of the adapter. Be sure to match the positive (+) wire of the controller cable to the positive (+ red) wire of the adapter, and the negative (-) wire of the controller cable to the negative (- grey) wire of the adapter (see figure 10).

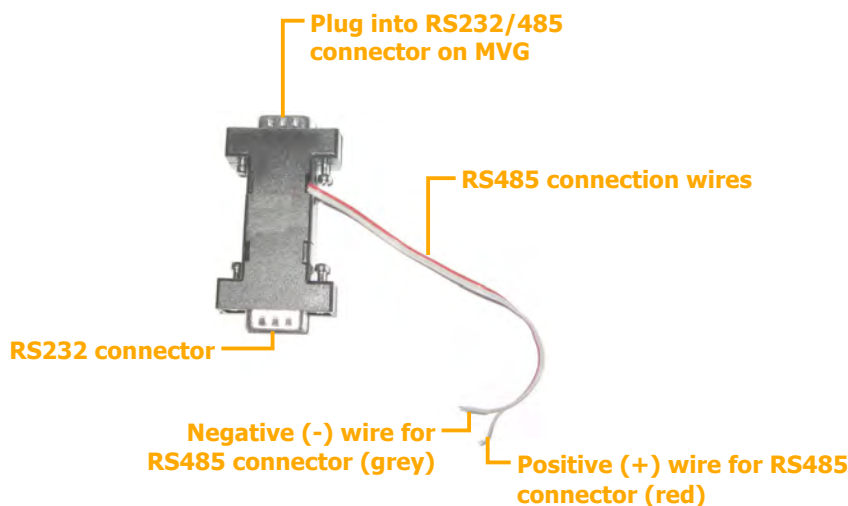

Figure 10: RS232/485 adapter

To connect multiple RS485 controllers to the adapter, insert the positive (+) wires of all of the controllers into one slot in the wire connector, and the negative (-) wires of all of the controllers into the other slot of the wire connector.



Figure 11: Wire connector

2. If multiple PTZ cameras are connected to the unit, configure each camera to use a different ID. For information about how to do this, refer to the camera documentation.
3. Connect the RS232/485 adapter to the **RS232/485** connector on the rear panel of the unit.

Connecting Sensors

Sensors are devices that detect events such as a door being opened, brakes being pressed, or high G-force pressure. Up to four dry-contact input sensors can be connected directly to the unit. In addition, if you wish, you can connect either an ADAM Data Acquisition Module or an IA-3126-2 relay board to the unit. Either of these devices makes it possible to connect up to 16 additional sensors to the unit.

Sensor 1 and Sensor 4 can be used as switches instead of sensors. The switches can be used to activate outlines and to change the display on a CCTV monitor.

Connecting a Sensor Directly to the Unit

The unit has four sensor connectors (**In1** – **In4**). You can use these connectors to connect up to four dry-contact input sensors directly to the unit. Alternatively, **In1** and **In4** can be used to connect switches as follows:

- **In1**: If you are defining more than one outline (alternate sets of recording and event-handling settings), you can connect a toggle (on-off) switch to **In1** instead of a sensor. The switch can then be used to change the active outline. For additional information, please refer to the *TVG System Guide*.
- Note:** Some alarm panels can also be connected to **In1**. When they are, they can function as automatic outline toggle switches. For additional information, please consult the alarm panel vendor.
- **In4**: If a CCTV monitor will be connected to the unit, you can connect a push-button switch to **In4** instead of a sensor. The button can then be used to change the display on the monitor. For additional information, see *Connecting a CCTV Monitor*, page 26 and refer to the *TVG System Guide*.

⇒ **To connect a sensor or switch directly to the unit:**

1. Install the sensor or switch in its desired location in accordance with the manufacturer's instructions.

Note: If the sensor requires an external power supply, you may be able to connect it to the **12VDC Power Out** connector on the rear panel of the unit. However, bear in mind that the unit can supply a maximum of 500 mA (6W) of power. If the devices connected to the unit require more than this amount of power, you must power some or all of them independently (see *Supplying Power to Devices Connected to the Unit*, page 13).
2. Connect the two wire contacts of the sensor or switch to the Sensors terminal block on the rear panel of the MVG, as illustrated in figure 12. Insert the wires into the connectors and tighten the screws below each connector to hold the wires in place.

Note: The wires must be connected to two adjacent contacts in the same group (e.g. the two contacts of “**In1**”), but the polarity does not matter.

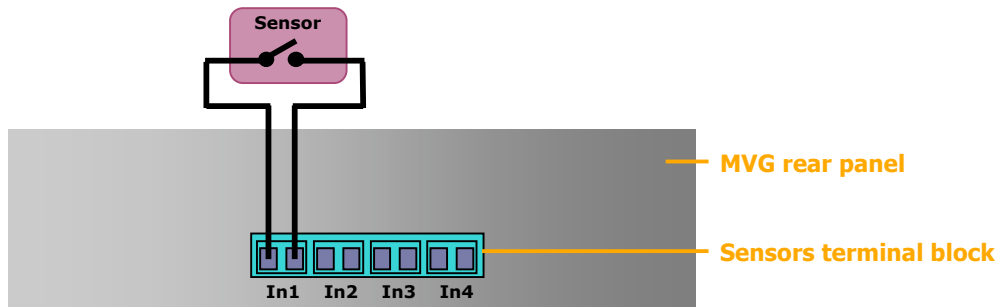

Figure 12: Connecting a sensor

Connecting Sensors Using an ADAM Module

If you want to connect additional dry sensors to the MVG, you can do so by connecting an ADAM Data Acquisition Module to the unit. Up to 16 additional dry sensors can then be connected to the unit through the ADAM module.

NOTE: Alternatively, you can connect additional sensors using an IA-3126-2 relay board, as explained *Connecting Sensors and Activators Using an IA Relay Board*, page 24.

To connect sensors using an ADAM module, you will need the following items:

- ADAM-4051 Data Acquisition Module (available from SerVision)
- ADAM-4520 isolated RS232->RS422/RS485 converter (available from SerVision)
- Flat ribbon cable with D-type 9-pin female connector on one end and a D-type 9-pin male connector on the other end
- Wire to connect the ADAM module to the ADAM converter – red, black, yellow, and green
- Wire and an electrical plug (optional) to connect the ADAM module to a power source (either a power supply from the unit or an independent connection)



Figure 13: ADAM-4051 module



Figure 14: ADAM-4520 isolated converter

NOTE: The instructions below explain how to connect sensors to the MVG using the ADAM module and converter described above. For additional information about connecting and configuring the ADAM module and converter, please refer to the manufacturer's documentation, or contact your vendor.

➡ To connect sensors using an ADAM module:

1. Install the sensors in their desired locations in accordance with the manufacturer's instructions.
2. Connect the wire contacts of each of the sensors to the terminal blocks of the ADAM-4051 module as follows:
 - Connect all of the negative (-) wires of all of the sensors to one of the ground (**D GND**) connectors on the ADAM module. If the wires cannot all be inserted into the connector, use a wire connector to connect them together, and then connect the wire connector to the ground (**D GND**) connector on the ADAM module.
 - Connect each of the positive (+) sensor wires to one of the numbered connectors (**D1 0** through **D1 15**) in the terminal blocks of the module.

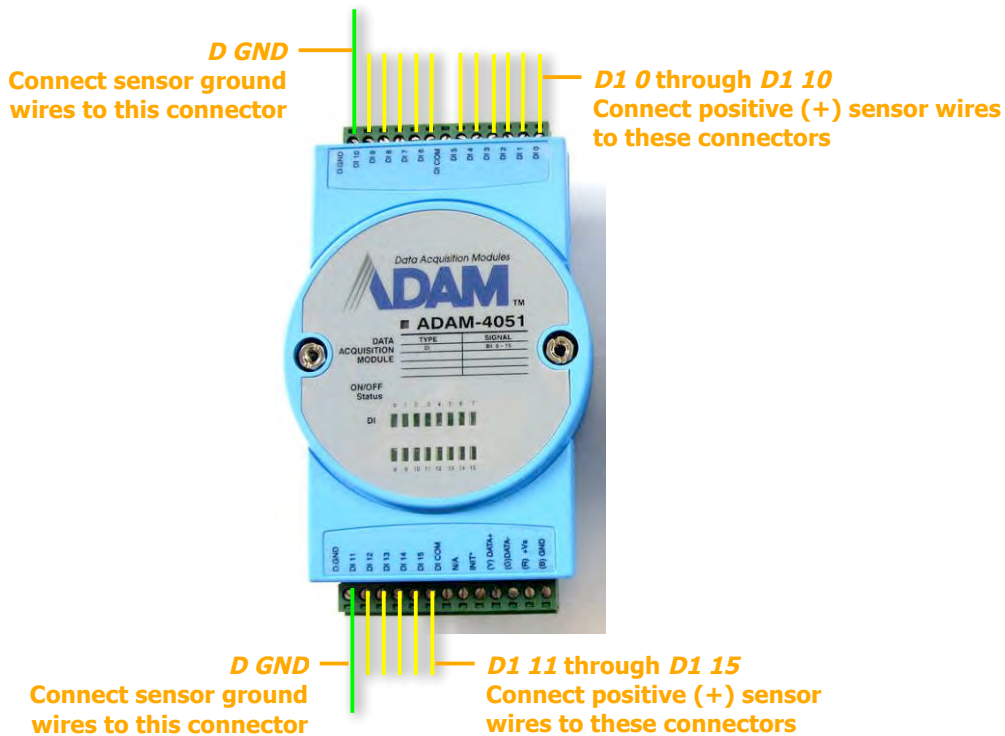

Figure 15: Connecting sensors to the ADAM-4051 module

3. Connect the ADAM-4051 module to the ADAM-4520 isolated converter as follows (see figure 17, page 23):

Connect this connector on the ADAM-4051	To this connector on the ADAM-4520
(Y) Data+	Data+
(G) Data-	Data-
(R) +Vs	(R)+Vs
(B) GND	(B)GND

4. Connect the ADAM-4520 isolated converter to the **RS232/485** connector on the rear panel of the MVG unit in one of the following ways:
 - If you are not connecting any RS485 PTZ controllers to the unit, using the 9-pin flat ribbon cable, connect the RS232 connector of the ADAM-4520 converter directly into the **RS232/485** connector.

- If you are also connecting one or more RS485 PTZ controllers to the unit, using the 9-pin flat ribbon cable, connect the RS232 connector of the ADAM-4520 converter into the RS232 connector of the RS232/485 adapter supplied with the unit. Connect the PTZ controllers to the adaptor as explained under *Connecting PTZ Controllers*, page 17. Then plug the adaptor into the **RS232/485** connector on the unit.

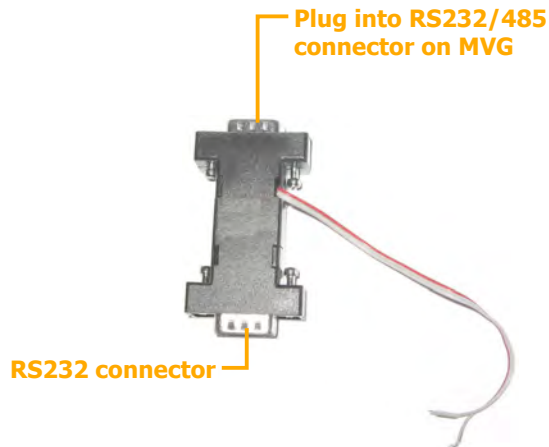

Figure 16: RS232/485 adapter

Note: If you connect an ADAM module to the unit, you cannot connect any RS232 PTZ controllers, a touch-screen controller, or an IA relay board to the unit. For additional information, see *Connecting PTZ Controllers*, page 17; *Connecting a CCTV Monitor*, page 26; *Connecting Sensors and Activators Using an IA Relay Board*, page 24.

5. Connect the ADAM-4051 module to the power source as follows (see figure 17, page 23):
 - Connect the positive (+) wire of the power supply cable to the **(R) +Vs** connector on the module
 - Connect the negative (-) wire of the power supply cable to the **(B) GND** connector on the module

Note: Each of the power connectors on the module will then have two wires connected to it – one connecting it to the power supply, and one connecting it to the power connectors of the ADAM-4520 converter.

Note: You may be able to use the MVG to supply power to the modules by connecting the power supply cables to the **12VDC Power Out** connector on the rear panel of the unit. However, bear in mind that the unit can supply a maximum of 500 mA (6W) of power. If the devices connected to the unit require more than this amount of power, you must power some or all of them independently (see *Supplying Power to Devices Connected to the Unit*, page 13).

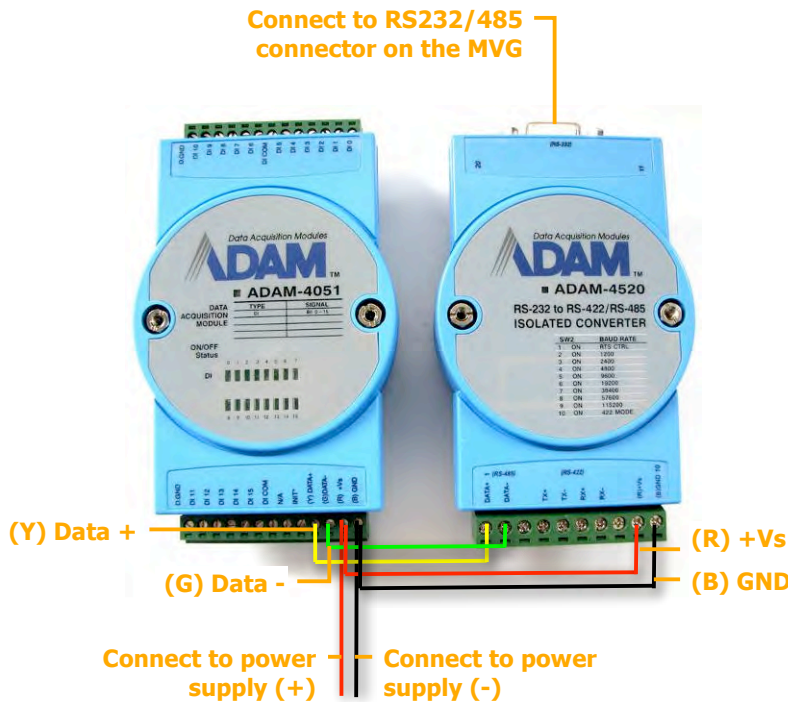

Figure 17: Connecting the module to the converter, the MVG, and the power supply

Connecting Activators

Activators are external devices such as alarms and lights that can be turned on by the system in response to an event. Essentially, the unit functions as an on/off switch for the device. The unit activates the activator by closing the circuit of its power supply. Two activators can be connected directly to the unit. In addition, if you wish, you can connect an IA-3126-2 relay board to the unit. This makes it possible to connect up to 16 additional activators to the unit (see *Connecting Sensors and Activators Using an IA Relay Board*, page 24).

In addition to the activator itself, you will need 16 AWG red and black cables to connect an activator to the unit.

➡ To connect an activator:

1. Install the activator in its desired location in accordance with the manufacturer's instructions.

Note: If the activator requires an external power supply, you may be able to connect it to the **12VDC Power Out** connector on the rear panel of the unit. However, bear in mind that the unit can supply a maximum of 500 mA (6W) of power. If the devices connected to the unit require more than this amount of power, you must power some or all of them independently. For additional information, see *Supplying Power to Devices Connected to the Unit*, page 13.

2. Connect the two contacts of the activator to the Activators terminal block on the rear panel of the MVG, as illustrated in figure 18.

Note: The wires must be connected to two adjacent contacts in the same group (e.g. the two contacts of “Out1”), but the polarity does not matter.

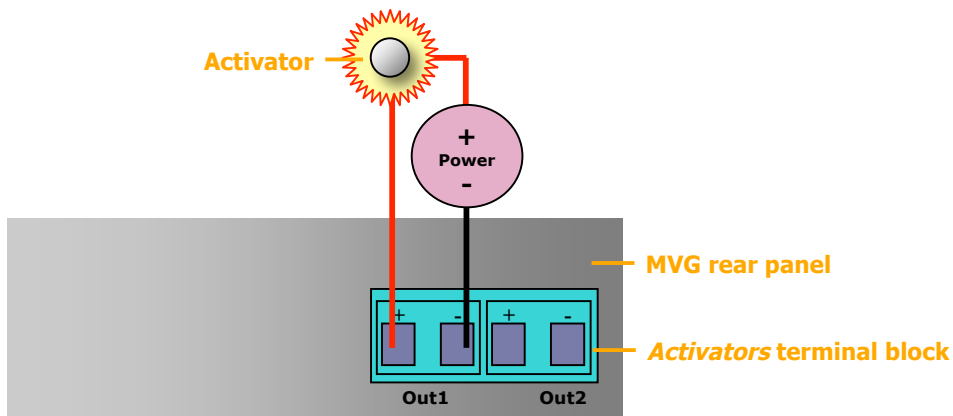

Figure 18: Connecting an activator that has its own power supply

Connecting Sensors and Activators Using an IA Relay Board

If you want to connect additional dry sensors and/or two activators to the MVG, you can do so by connecting an Intelligent Appliance IA 3126-2 relay board to the unit. Up to 16 additional dry sensors and 16 additional activators can then be connected to the unit through the relay board. Sensor and activator events from devices connected to an IA relay board can be seen in SerVision client applications and activators can be turned on and off via these applications. However, the sensors and activators cannot be configured using the MVG’s configuration utility.

NOTE: Alternatively, you can connect additional sensors using an ADAM module, as explained under *Connecting Sensors Using an ADAM Module*, page 20. Sensors that are connected through an ADAM module can be configured using the MVG’s configuration utility.



Figure 19: IA 3126-2 relay board

For information about connecting sensors and activators to the IA 3126-2 relay board, and about connecting the relay board to a power source, please consult the relay-board’s documentation.

NOTE: If you are connecting less than 16 activators or 16 sensors to the relay board, be sure to connect them to the relay beginning with the lowest connector, and do not leave open connectors between those that you use. For example, if you are connecting 4 activators and 3 sensors, connect the activators to output connectors 1-4 on the board and the sensors to input connectors 1-3 on the board.

➤ To connect the IA 3126-2 relay board to the MVG:

1. Set the ID of the relay board to 0. (For information about how to do this, consult the relay-board documentation.)
2. Connect the relay board to the **RS232/485** connector on the rear panel of the MVG unit in one of the following ways:
 - If you are not connecting any RS485 PTZ controllers to the unit, using a 9-pin flat ribbon cable, connect the RS232 connector of the relay board directly into the **RS232/485** connector.
 - If you are also connecting one or more RS485 PTZ controllers to the unit, using a 9-pin flat ribbon cable, connect the RS232 connector of the relay board into the RS232 connector of the RS232/485 adapter supplied with the unit. Connect the PTZ controllers to the adaptor as explained under *Connecting PTZ Controllers*, page 17. Then plug the adaptor into the **RS232/485** connector on the unit.

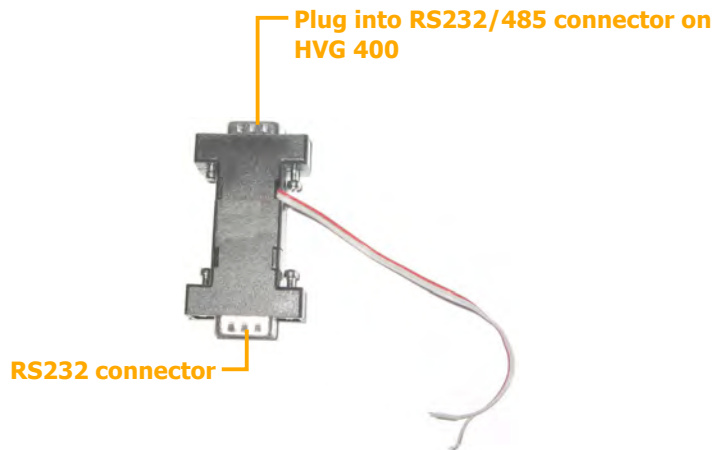

Figure 20: RS232/485 adapter

Note: If you connect a relay board to the unit, you cannot connect any RS232 PTZ controllers or an ADAM module to the unit. For additional information about connecting PTZ controllers to the unit, see *Connecting PTZ Controllers*, page 17. For information about connecting an ADAM module to the unit, see *Connecting Sensors Using an ADAM Module*, page 20.

Connecting Microphones

Up to two microphones can be connected to the unit, one active and one passive. When one or two microphones are connected, you can hear and record sound along with video images. The sound from a microphone can be associated with any or all of the cameras in the unit's configuration. (For additional information, please refer to the *TVG System Guide*.)

Microphones can be connected to one or both of the **Audio In** connectors (**Ain1** and/or **Ain2**). Passive microphones, which require external amplification, must be connected to **Ain1**. Active (self-amplifying) microphones must be connected to **Ain2**. Microphones with an output voltage of 1 Vrms or 1.41 Peak are supported.

⇒ **To connect a microphone:**

1. Install the microphone in the desired location.
2. Plug the microphone connector into the desired **Audio In** connector (**Ain1** or **Ain2**).

Connecting a Speaker or Headphones

The MVG unit contains a built-in, 1-watt, internal speaker, which is located on the right side of the unit. You can also connect an external speaker or headphones to the unit. The speakers (and headphones) allow you to hear audio that is transmitted from one of the client applications. The external speaker or headphones can be used in addition to the internal speaker or instead of it. (For additional information, please refer to the *TVG System Guide*.)



Figure 21: Internal speaker

⇒ **To connect a speaker or headphones:**

1. Install the speaker in its desired location, if necessary.
2. Plug the speaker or headphone connector into the **Audio Out (Aout)** connector.
3. If the speaker requires an independent power supply, connect its power supply cable to an electrical outlet.

Connecting a CCTV Monitor

You can connect a CCTV monitor to the unit. The monitor offers an alternative way to view live video from the MVG. It is primarily useful if you want to view video when the user is near the unit. For example, if the MVG is set up in a bus, the driver can use a CCTV monitor to keep tabs on parts of the bus that cannot be seen from the driver's seat.

The following types of monitors can be used:

- Surveillance monitors: Monitors that are designed to be plugged directly into surveillance cameras.
- Entertainment monitors: Monitors that are intended to be plugged into portable DVD players in vehicles.
- Standard television sets with AV connectors

When choosing a monitor to connect to the unit, ensure the monitor supports the video format used by the cameras (NTSC or PAL). Some SECAM monitors will also work when the PAL video format is used.

If you choose a monitor with touchscreen support, you can use the monitor to view recorded video as well as live video. For information about recommended types of touchscreen monitors, please consult your vendor.

NOTE: If you are connecting an RS232 PTZ controller or an ADAM module to the unit, you cannot use touchscreen functionality because the RS232 serial port is not available. For additional information, see *Connecting PTZ Controllers*, page 17; *Connecting Sensors Using an ADAM Module*, page 20.

To connect the monitor to the MVG, you will need a cable with the following connectors:

- An appropriate connector (BNC or RCA) for the Video In connector of the monitor. (Consult the monitor documentation or your vendor to find out which kind of connector is required for the particular monitor you are using.)
- A BNC male connector to connect to the **TV Out** connector of the MVG. (A cable with an RCA connector can be used by attaching a BNC-to-RCA adaptor to the connector. See figure 9, page 17.)

To connect the output of a touchscreen to the unit, you will need a cable with the following connectors:

- An appropriate connector to connect to the touch output connector on the monitor
- A female 9-pin RS232 connector to connect to the MVG's **RS232/485** connector.

An appropriate cable should be supplied with the monitor.

⇒ **To connect a CCTV monitor:**

1. Install the monitor in its desired location.
2. Connect the Video In connector of the monitor to the **TV Out** connector of the MVG, using a cable with an appropriate connector (BNC or RCA) for the Video In connector of the monitor on one end, and a BNC male connector on the other end.

Note: If you are using a standard television set as a monitor, use the television's AV connector as the Video Input connector.

3. If the monitor is touch-sensitive, connect the touch output to the **RS232/485** connector as follows:
 - If you are not connecting any RS485 PTZ controllers to the unit, connect the RS232 connector of the touch output cable directly into the **RS232/485** connector.
 - If you are also connecting one or more RS485 PTZ controllers to the unit, connect the RS232 connector of the touch output cable to the RS232 connector of the RS232/485 adapter supplied with the unit (see figure 22 below). Connect the PTZ controllers to the adaptor as explained under *Connecting PTZ Controllers*, page 17. Then plug the adaptor into the **RS232/485** connector on the unit.

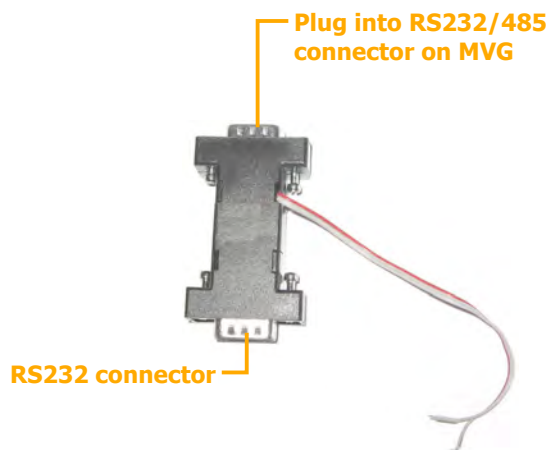

Figure 22: RS232/485 adapter

4. If the monitor is touch-sensitive, it is recommended that you calibrate it before you use it. For information about how to calibrate the monitor, please refer to the monitor's documentation.

Connecting a Switch

If you wish, you can connect a switch to the unit to change the display on the monitor. The switch must be connected to the Sensor 4 (**In4**) connector. For additional information, see *Connecting Sensors*, page 19 and refer to the *TVG System Guide*.

Connecting Multiple Monitors

If you wish, you can connect multiple CCTV monitors to the MVG. For example, you may wish to have one monitor beside the driver's seat and another beside the conductor's seat.

To connect multiple monitors, you must use video splitters to split the connection. Bear in mind, however, that the image quality in each of the monitors will be slightly degraded. To correct this problem, you can use a video amplifier (booster) for each monitor. To ensure you have the correct equipment, consult a video equipment supplier.

Setting Up Network Connections

The MVG has a built-in router that is used to connect the video-gateway component of the unit to external networks such as the internet or a cellular network. The router can connect to more than one external network at a time. For example, it can connect to a cellular network and to a LAN simultaneously.

The router manages a small local network (LAN) that can include up to four devices – the video gateway itself and up to three other devices. For example, you could connect a PC and an IP-based cash box to the router, and they would both be part of the MVG's LAN. The devices connected to the router can connect to external networks through the router. In addition, the router can be configured to allow connections from external networks to the devices in the internal network.

NOTE: The router is configured using the MVG's configuration utility. For additional information, please refer to the *TVG System Guide*.

Connecting the MVG to an External Network

You can connect the router to a LAN, a cellular network, and/or a WiFi access point.

⇒ **To connect the MVG unit to an external LAN:**

- Connect the **Ethernet Out** connector on the rear panel of the MVG unit to a LAN connection point (a hub, wall socket, or any other connection point) using the supplied Ethernet (network) cable.

⇒ **To connect the MVG unit to an external cellular network:**

- Connect a supported cellular modem that has a USB adaptor to one of the USB ports on the rear of the unit. To ensure good reception, use a USB extension cord to connect the modem to the USB port, and place the modem in a relatively exposed location as high up in the vehicle as possible. The USB extension cord should not be longer than 1.5 meters.

Note: It does not matter which USB port you use. Do not, however, connect more than one cellular modem to the MVG at one time.

Note: In most cases, remote client devices cannot connect directly to the unit over a cellular network. If you want to use a cellular network to connect to the MVG, you will probably have to use a SerVision proxy server. For additional information, please refer to the *TVG System Guide* or contact your vendor.

⇒ **To connect the MVG unit to an external WiFi network:**

- Connect a supported WiFi card with a USB adaptor to one of the USB ports on the rear of the unit.

Note: If the unit is already running, restart it after you connect the WiFi card.

Note: It does not matter which USB port you use. Do not, however, connect more than one WiFi card to the MVG at one time.

Connecting Devices to the MVG's Internal Network

Up to three IP-based devices can be connected to the MVG's local network. The MVG's router contains a DHCP server that can automatically assign IP addresses to devices that are plugged into its Ethernet ports. If you will need to access a connected device remotely, you can configure the device to acquire its IP from this DHCP server. In this case, the device will be able to connect to the external network, but remote devices will not be able to access it. If you want to access the device remotely, you should manually configure its IP address and other network settings, as described below, and set up port forwarding for the device as described in the *TVG System Guide* under *Port Forwarding*.

NOTE: The video gateway component of the MVG automatically connects to the router component when the unit starts up. The router's DHCP server assigns an IP address to the video gateway component and port forwarding is automatically configured.

⇒ **To connect a device to the MVG's local network:**

- Connect the network connector of the device to one of the **Ethernet In** connectors on the rear panel of the MVG.

If you are configuring the device to enable remote access to it, set its network settings as follows. (For information about how to configure the network settings of the device, consult the device's documentation.)

Setting	Value
IP Address	Assign a static IP address to the device. The IP must be in the range 172 . 20 . 233 . 2 through 172 . 20 . 233 . 99.
Mask	255 . 255 . 255 . 0
Gateway	172 . 20 . 233 . 1
DNS	172 . 20 . 233 . 1

Connecting the GPS Antenna

A GPS receiver is built into the unit. When the GPS antenna is connected to the unit, this receiver can be used to track the location of the vehicle in which the MVG is installed.

⇒ **To connect the GPS antenna:**

1. Connect the supplied GPS antenna cable to the **GPS Antenna** connector on the rear of the unit.
2. Place the other end of the antenna as high up as possible in the vehicle or on the roof of the vehicle. Make sure the box at the end of the antenna is horizontal and is facing up (smaller side up). If possible, place it in a location in which there are no obstructions between it and the sky.



Figure 23: GPS antenna cable

The box at the end of the antenna contains a magnet with which you may be able to attach it to the roof of the vehicle. Alternatively, you can attach it in its intended location with double-sided tape. Regardless of which method you use, make sure the antenna is attached securely to the vehicle so that it will not come loose when the vehicle moves.

Connecting the MVG to a Power Source

The **Power** connector of the MVG can be connected either to the vehicle battery or to a standard electrical outlet. Once it is connected, it starts up automatically. During the start-up process, the LEDs on the front of the unit flash at various intervals. When the start-up process is completed successfully, the **Power** LED should display as a solid color and blink momentarily every second. (Depending on the configuration settings, it should either be solid orange and then blink green or solid green and then blink orange.)

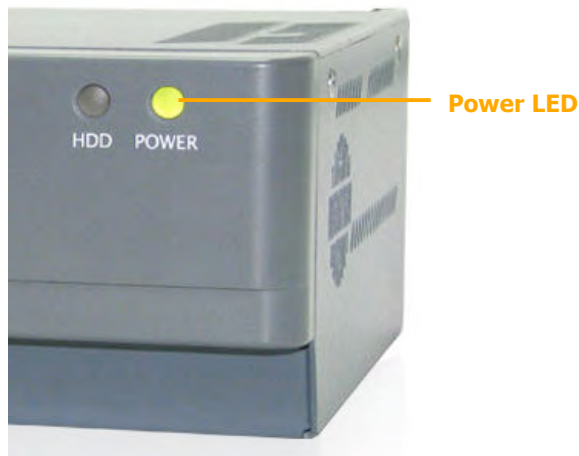

Figure 24: Power LED

NOTE: When the start-up process is completed, if the **Power** LED does not flash – it displays as a solid green or orange all the time – the start-up process was not successful. In this case, disconnect the unit from the power supply and then reconnect it.

NOTE: It is recommended that only a vehicle installation specialist connect the unit to the battery.

Connecting the Unit to the Vehicle Battery

Normally, the unit is connected to the vehicle battery and to the ignition using 16 AWG cable (not supplied). This can be done in one of two ways:

- Connecting the unit directly to the battery and the ignition
- Connecting the unit to a power source in the vehicle that is only active when the ignition is on

When the unit is connected to the battery and ignition in one of these ways, it automatically powers up when the ignition is switched on. If the unit is connected directly to the battery, it can be configured to operate only when the vehicle ignition is on or to shut down automatically soon after the ignition is turned off. Otherwise, it will shut down automatically when the ignition is turned off.

For testing and evaluation purposes, the unit can also be powered by connecting it to the vehicle's cigarette lighter, if the vehicle has one. This method connects the unit to the battery and the ignition quickly and easily, but it is not normally suitable for permanent connections, because it is difficult to install the unit and the wiring securely in appropriate locations when this method is used.

In addition, it is possible to connect the unit to the battery alone, without connecting it to the ignition. In this case, the unit runs continuously, whether the ignition is on or not, as long as the battery can supply power to it. Because

of the drain on the battery, connecting the unit in this way is also only recommended for limited periods of time for testing and evaluation purposes.

NOTE: The ignition connector (**IGN**) of the **Power** connector **MUST** be connected. If it is not, the unit will not start. If you wish to use the vehicle's ignition connection, connect it to this connector. Otherwise, short this connection to the positive (+) connector of the **Power** connector block. For additional information, see step 5 below (pp. 33–34).

NOTE: To connect the unit only to the battery, 16 AWG red and black cable (not supplied) is required.

⇒ **To connect the MVG to the vehicle battery:**

1. Remove the wire connector from the end of the supplied power cord.



Figure 25: Wire connector

2. Plug the wire connector into the **Power** connector on the rear panel of the unit and tighten the screws to secure it.

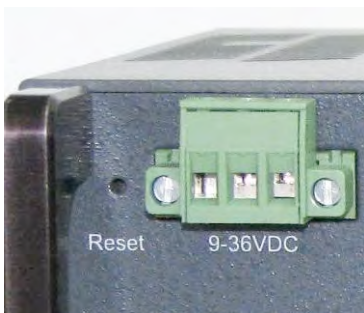

Figure 26: Wire connector plugged into Power connector

3. Using 16 AWG red cable, connect the unit to the vehicle battery as follows:
 - Connect one end of the red wire to the positive (+) connector of the Power wire connector (the middle connector in the block).
 - Connect the other end of the red wire to the positive (+) connector of the vehicle battery or power source
4. Using 16 AWG black cable, connect the unit to the vehicle battery as follows:
 - Connect one end of the black wire to the negative (-) connector of the Power wire connector (the right connector in the block).
 - Connect the other end of the black wire to the negative (-) connector of the vehicle battery or power source
5. If you need to connect the unit to the ignition, using 16 AWG black cable, connect the **IGN** connector to the ignition, as illustrated in figure 27. If you do not need to connect the unit to the ignition, using 16 AWG black cable, connect the **IGN** connector to the positive (+) connector of the **Power** connector (the middle connector in the block), as illustrated in figure 28.

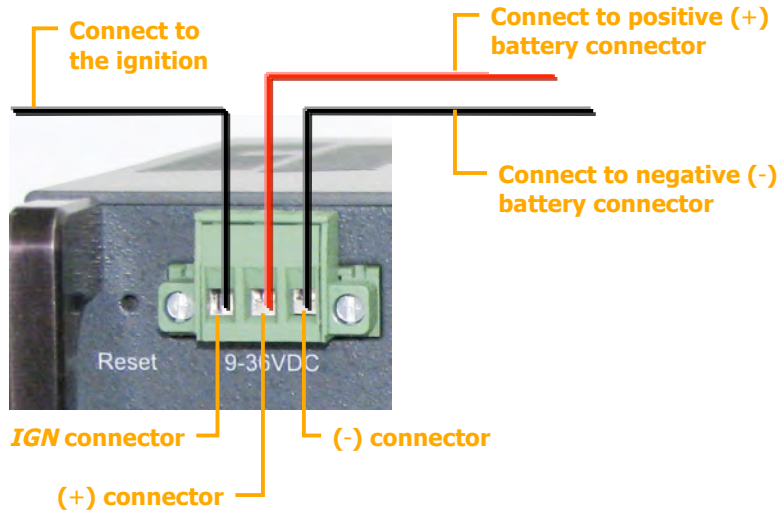

Figure 27: Connecting the MVG to the vehicle battery and the ignition

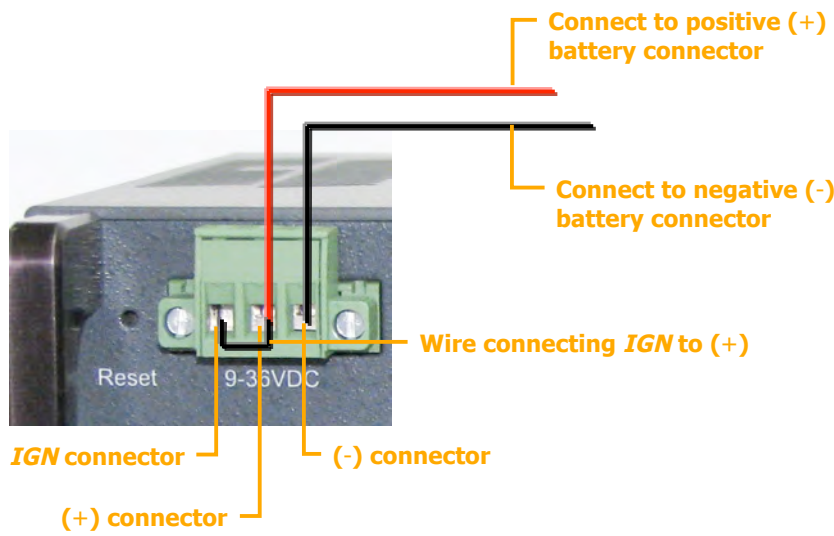

Figure 28: Connecting the IGN connector to the (+) connector when a connection to the ignition is not required

⇒ To connect the MVG to the vehicle's cigarette lighter:

- Use the supplied power cord to connect the **Power** connector on the rear panel of the unit to the vehicle's cigarette lighter.



Figure 29: Power cord

Connecting the Unit to an Electrical Outlet

If a standard electrical outlet is available, the unit can be connected to it. For example, if you want to configure or test the unit indoors, you can power the unit in this way. The power-supply cable has a built-in switch. The switch mimics the ignition switch of a vehicle: when the switch is in the ON position, the "ignition" is on, and when it is in the OFF position, the "ignition" is off.

WARNING: Only the power supply cable that came with the unit should be used to connect the unit to an electrical outlet. Use of a power supply other than the one provided in the package may cause irreparable damage to the unit.

⇒ To connect the MVG to a standard electrical outlet:

1. Use the supplied power supply cable to connect the **Power** connector to the outlet.

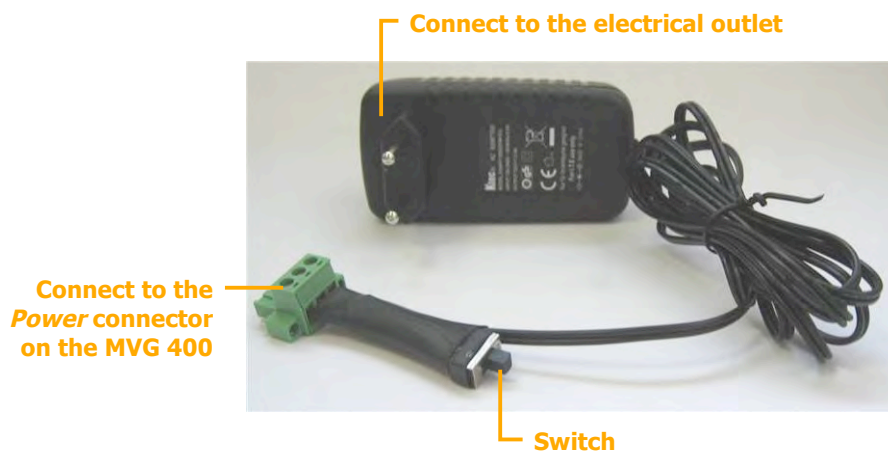

Figure 30: Power supply cable

2. Push the switch on the cable to the ON position. The "ignition" is on.

Appendix: Removing the Unit's Hard Drive

The hard drive of the MVG can easily be removed and replaced with another one. This may be a convenient way to review or download video from the hard drive. For example, if MVG units are installed in a fleet of buses, you may want to remove the hard drive from each bus when it comes into the bus depot, and replace it with a different hard drive. You can then insert the hard drive into an MVG at the yard office and view or download the video from it.

NOTE: For information about acquiring additional hard drives that are compatible with the MVG, please consult your MVG vendor or SerVision technical support.

⇒ To remove the hard drive from the MVG unit:

1. Disconnect the MVG from the power supply.
2. On the left side of the unit, loosen the screws on the cover of the hard-drive compartment, and then remove the cover.



Figure 31: Hard-drive compartment cover

3. Loosen the screws that secure the hard-drive platform in the compartment.

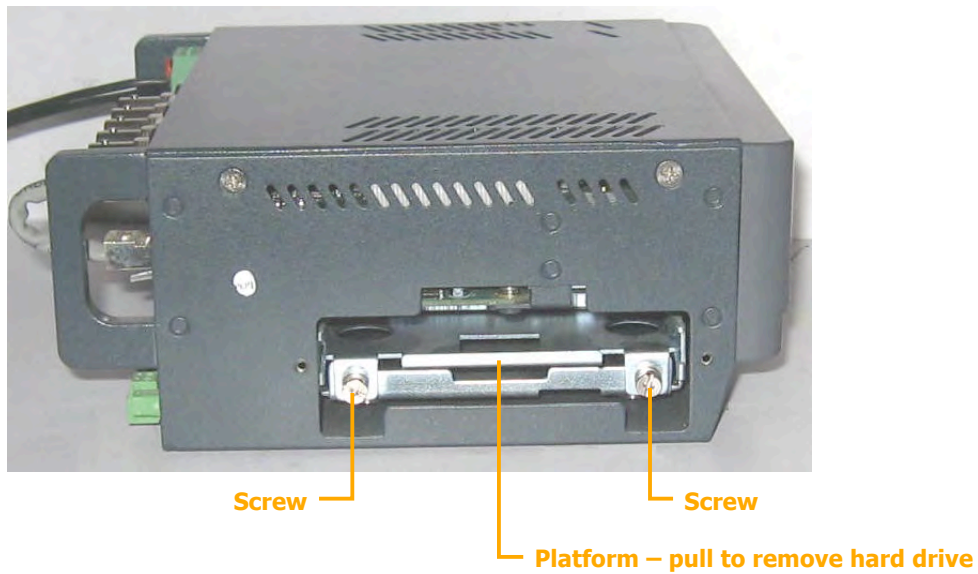

Figure 32: Hard-drive platform in open compartment

4. Pull the hard-drive platform out of the unit.

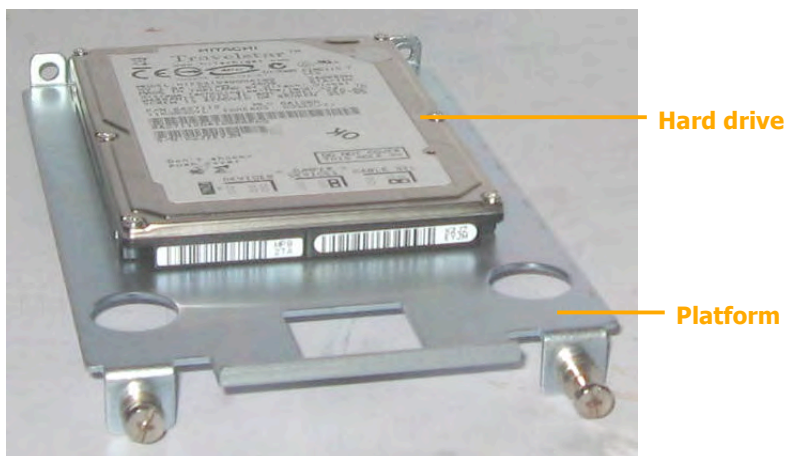

Figure 33: Hard drive on platform

⇒ To insert a hard drive into the unit:

1. Slide the hard-drive platform into the hard-drive compartment.
2. Tighten the screws that secure the platform in the compartment (see figure 32).
3. Place the compartment cover over the compartment, and secure it in place by tightening the screws (see figure 31).

SerV^{ision}

POB 45205 Jerusalem 91450 Israel

Tel: +972-2-535 0000 • Fax: +972-2-586 8683

www.servision.net • info@servision.net